

Technical and Economic Assessment of the Integration of Refrigeration Concepts into the Proceeding Extension of Solar Energy Systems in Brazil

Christopher Wiencke¹, Giovani Ávila^{1,*}, Katja Biek²

¹Universidade Federal do Rio de Janeiro, Brasil, christopher.wiencke@poli.ufrj.br

²Berlin University of Applied Sciences and Technology, biek@bht-berlin.de

* Correspondence: giovani@poli.ufrj.br

Received: 11 Dec 2023,

Receive in revised form: 15 Jan 2024,

Accepted: 25 Jan 2024,

Available online: 04 Feb 2024

©2024 The Author(s). Published by AI Publication. This is an open access article under the CC BY license (<https://creativecommons.org/licenses/by/4.0/>)

Keywords— solar energy; self-generation; solar powered cooling

Abstract— Electricity is the main source used in the refrigeration process of environments and machines. Global warming and the expansion of the tropical belt increase the demand for refrigeration. The use of solar-assisted air conditioning has a great potential, especially in subtropical regions with high solar radiation contributing to demand's fulfillment and reducing electricity from non-renewable sources. It has cooling potential in buildings reducing electricity's peak demand, ecological footprint reducing carbon emissions and building's thermal load using ecological refrigerants. Also benefits the urban microclimate absorbing solar irradiation into the rooftop. The objective of this article is to survey the factors that influence the selection of components for a solar-assisted cooling system in buildings under different climatic conditions using an exploratory methodology based on the bibliography and on a survey of the state of the art describing the fundamental aspects and components of this technology, its function, and benefits. Non-thermally driven applications were also considered, such as conventional steam compression chiller, driven by electricity and compression cycle by photovoltaic energy. Different cooling systems at full load are compared. The research was applied in a school building in the city of Rio de Janeiro, concluding that solar-assisted refrigeration is an energetic and environmentally competitive alternative compared to compressors powered by electricity in conventional refrigeration systems.

I. INTRODUCTION

The cooling process of environments present an increasing energy demand due to global warming, desertification, and the expansion of the tropical belt as Figure 1. In subtropical regions, a high supply of solar radiation and a high demand for cooling occur simultaneously.

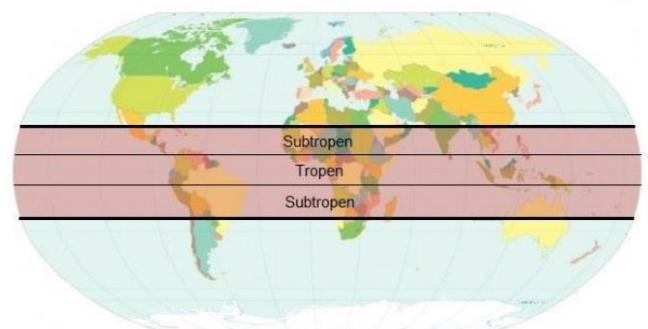

Fig.1. Tropical Belt.

The solar cooling provides a significant potential of an electrical energy reduction for air-conditioning in buildings, arranges fossil fuel savings and decreases peak demands of electrical energy.

Furthermore, solar cooling decreases the ecological footprint of tropical cities due to achieving carbon emission reduction and using environmentally friendly refrigerants. The solar array yields thermal load reduction of the building.

Finally, it impacts in a positive way the urban microclimate through absorbing the solar irradiation on the roof as in Figure 2.



Fig.2. Thermal Solar Array and Split Coolers with Compressor Operation.

Solar cooling systems (SCS) have the advantage that the maximum solar radiation corresponds to the maximum cooling demand in residential buildings.

SCS offer potential to reduce electricity consumption for building cooling and environmental footprint due to reduction in carbon emissions and use of ecological

refrigerants. In addition, the technology has a positive impact on peak electricity demand associated with conventional cooling, the need for transmission and distribution networks, and the ability to cool at night using thermal storage.

The following are factors that influence the selection of components for a solar-assisted cooling system in buildings.

The basic characteristics of equipment supported by solar energy in buildings, conventional compression equipment powered by electricity and photovoltaic energy.

1.1. Solar Energy

Brazil receives solar energy in the order of 10^{13} MWh per year, which is about 50.000 times the country's annual consumption of electricity, as in Figure 3 [2].

The country has an average solar radiation of 5 kWh/(m² day) and a cooling demand up to 200 W/m².

In Europe, where the most solar cooling systems are in operation, the average solar radiation is around 3 kWh/m²/day.

II. KNOWLEDGE BASE

In system modeling the recommendation of the technology is a function of the characteristics and survey of which techniques are available and are more efficient for the specific case. It is necessary to determine the correlation between solar energy supply and cooling demand. Solar energy can be converted into cooling using two principles: (1) Heat generated by solar thermal collectors can be converted into cooling using thermally driven chiller using physical sorption phenomena in a thermodynamic cycle; (2) electricity is produced in photovoltaic modules and can be converted into cooling using steam compression cycles. Figure 4 shows the first principle, heat-driven cooling systems that are usually applied for residential comfort cooling and so-called LowEx concepts. The second principle – solar electricity driven cooling (PV cooling) – is not commercially widespread, but frequently used to run solar driven refrigerators for cooling medicine in remote, sunny regions [2].

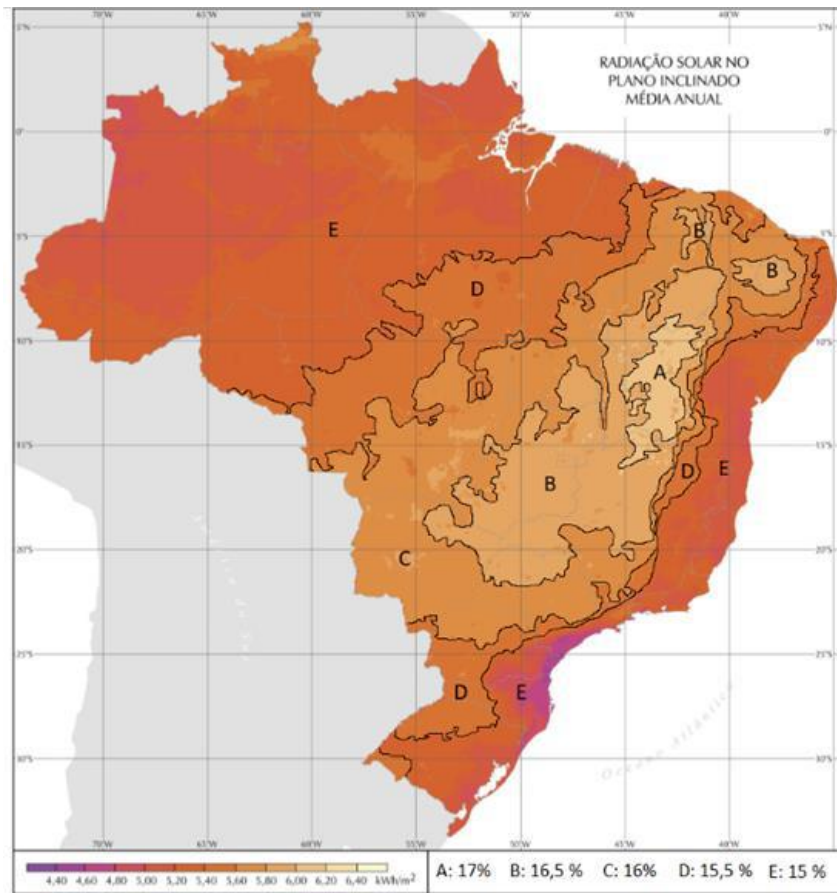

Fig.3. Annual average solar irradiance in Brazil.

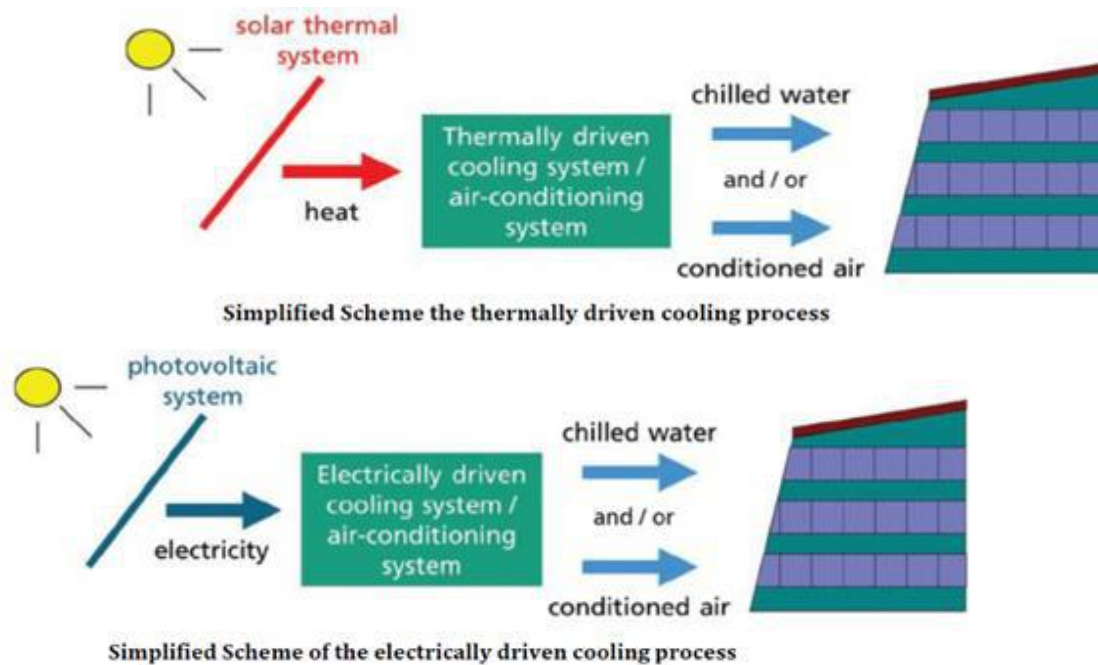

Fig.4. Schemes of SCS driven thermally and electrically [1], [8], Adapted.

Brazil’s National Electric Energy Agency has passed a law requiring energy distributors to inject generated

electricity into the grid. Brazil receives solar energy in the order of 1013 MWh per year, which is about 50,000 times

its annual electricity consumption. Its average solar radiation is 5 kWh/(m²day) and a cooling demand of up to 200 W/m². In Europe, the average solar radiation is about 3 kWh/(m²day) and the cooling demand is only 40-70 W/m². These data show the good conditions for solar refrigeration applications in Brazil [3].

2.1. Solar Thermal Collector

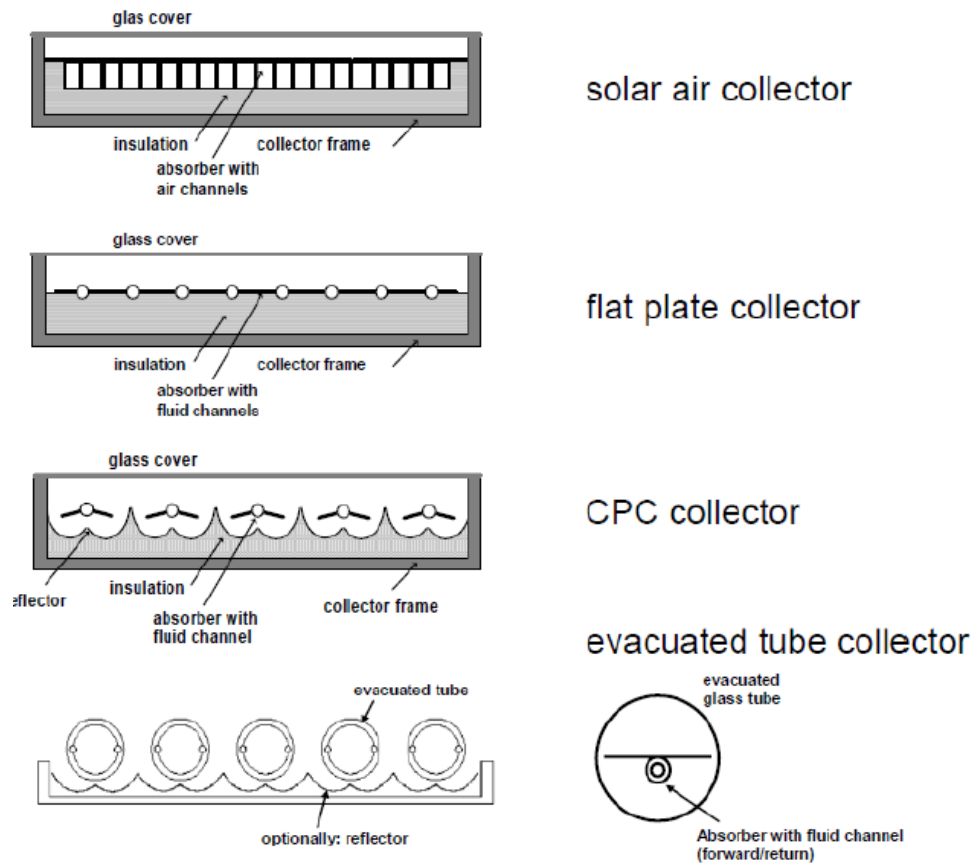

Fig.5. Types of stationary solar collectors, applicable in refrigeration [1].

The flat collector is applicable in the temperature range of up to 90°C. Heat losses are minimized by enhanced insulation and an additional convection barrier (Teflon sheet) between the glass cover and the absorber. The use of solar air collectors in the construction of flat plates is limited to descant cooling systems since this technology requires the lowest driving temperatures (from approx. 50°C) and allows under special conditions the operation without thermal storage. To operate thermally driven chillers with solar heat, high-quality flat plate collectors (selective

In Brazil a variety of solar thermal collectors is available in the market, and several are used in refrigeration systems. The appropriate type of collector depends on the selected cooling technology and local conditions, especially radiation availability. The general types of stationary collectors are shown in Figure 5

coating, improved insulation, high stagnation safety) [3]. Figure 6 shows two principles of vacuum tube collectors. On the left, the classic principle is shown, requiring a vacuum-tight seal. In the center, the principle of the thermos is shown [1]. On the right the application of the heat tube principle. The tube is protected from freezing and stagnation. There is a variety of vacuum tube collectors, for example, collectors with direct flow of the collector fluid through the absorber tube. The glass tube can follow the traditional principle, sealed at both ends, or the thermos principle. [4].

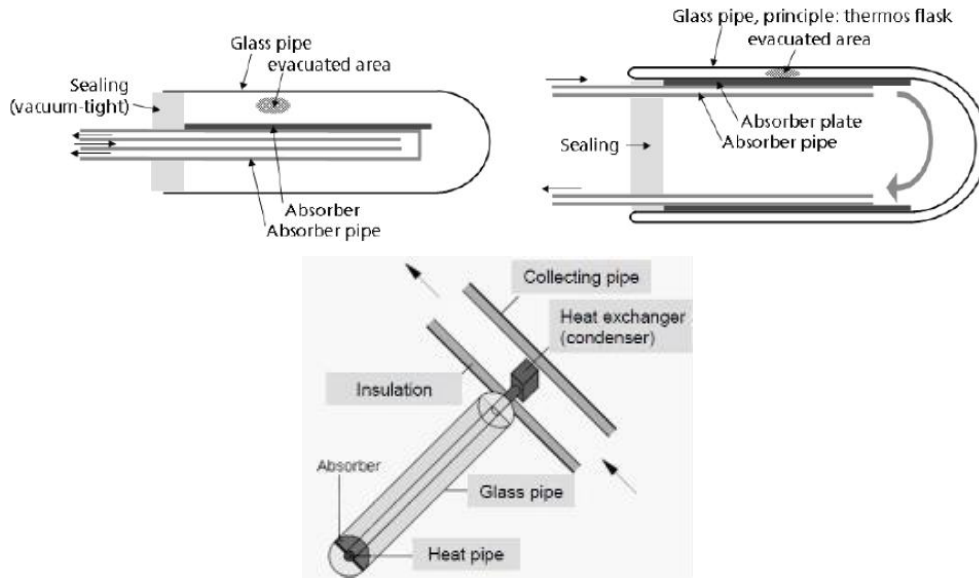

Fig.6. Different constructions of vacuum tube collectors [1].

Henning [5] raised the characteristics and Reichardt [3], the costs of thermally driven refrigerators in the Brazilian market.

2.2. Photovoltaic

A photovoltaic (PV) system consists of an arrangement of components to absorb and convert sunlight into electricity. The largest PV systems are connected to the network while the small ones normally don't. It is possible to operate a cooling system using a PV system. Two technical solutions can be used for SCS with photovoltaic systems: (1) Electricity-based system, connected to the grid, for indirect operation of the chiller with energy compensation. The

investment cost is about €3,000/kW (material only, 2017); (2) Electricity-based system for direct coupling with chiller for cooling food and medicines being sometimes the only solution in remote areas [3]. Figure 7 shows a comparison between a direct coupling photovoltaic system and a solar thermal system, indicating the COP (performance coefficient) and the efficiency of each system. The COP of the solar system/sorption can be increased using a collector with greater efficiency, for example, some special types of vacuum tube collectors have a maximum efficiency of 60% to 90°C of water temperature. Normal flat plate collectors with selective coating have efficiency at this temperature level of only 40% [3].

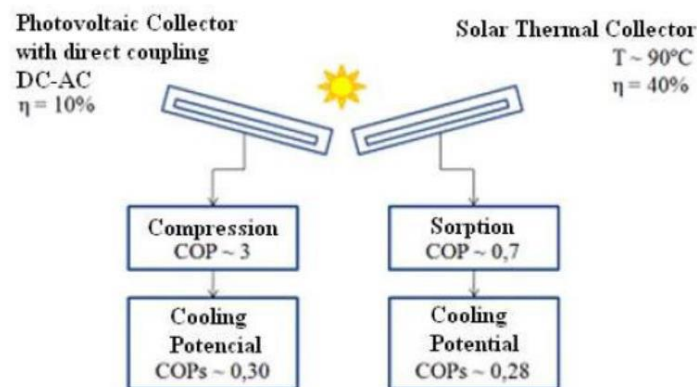

Fig.7. COP comparison and efficiency between a direct coupling photovoltaic system and a solar thermal system [6].

2.3. Cooling Systems

SCS uses heat in a heat-driven cooling process. Within SCS, there are two main processes: (1) closed cycles, where thermally driven absorption and adsorption produce chilled water for use in ambient conditioning equipment (air

handling units, fan coils, chilled beams, etc.); Open cycles, also called desiccant evaporative cooling systems (DEC), typically use water as a refrigerant and a desiccant as a sorbent for direct air treatment in a ventilation system. For closed cycle systems, Figure 8, there are two types of

sorption processes: adsorption and absorption-based systems. Based on closed cycle sorption; the basic physical process that underpins both technologies consist of two chemical components, serving as refrigerant and sorbent.

The water from the chiller is produced and transferred to the decentralized units such as fan coils, chilled ceiling, or AHU [1]. The efficiency of closed cycle systems may vary depending on the driving temperature.

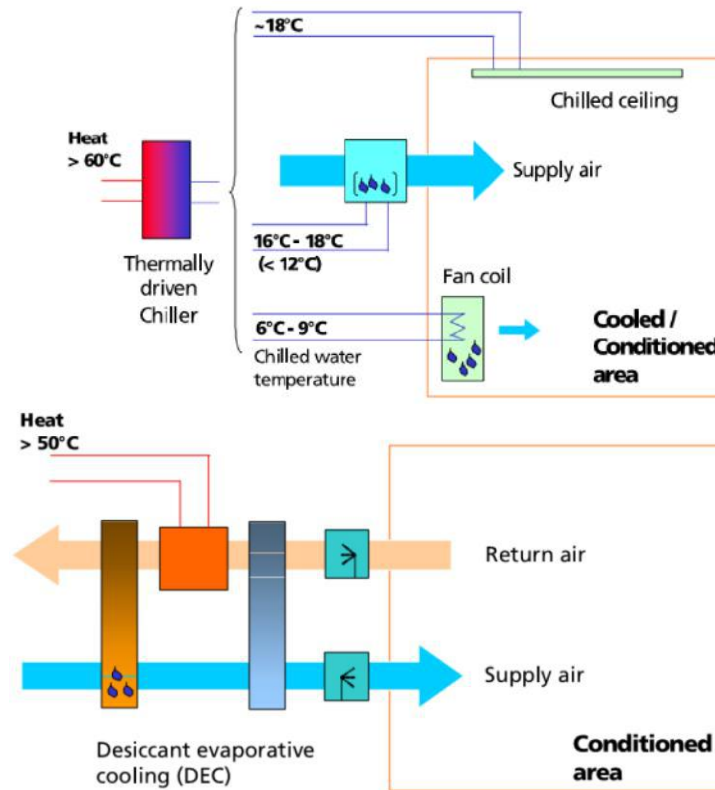

Fig.8. Closed cycle system at the left and open cycle system at the right.

While closed cycle systems produce chilled water open cooling cycles produce air conditioning directly. Thermally driven open cooling cycles are based on a combination of evaporative cooling and air dehumidification by a desiccant (a hygroscopic material that absorbs moisture), Figure 6. The supply air is cooled and dehumidified directly in an air handling unit (AHU) [7]. Desiccant cooling systems are an option with centralized ventilation systems offering the ability to pre-condition the air that enters a room. Open cycle SCS offers humidity management as well as space cooling. Solar thermal cooling does not use refrigerants (CFCs and HCFCs, used in electric compression chillers). Recent technology is desiccant cooling (DEC) where air is conditioned directly, e.g., cooled, and dehumidified, exploit the potential of sorption materials for air dehumidification - such as silica gel. In an open cooling cycle, this dehumidification effect is used for two purposes: to control the

humidity of the ventilation air in air-handling units and reduce the supply temperature of ventilation air by evaporative cooling [5].

2.3.1. Absorption Chiller

Absorption chillers use heat to provide cooling. Thermal compression of the refrigerant is obtained using a liquid refrigerant/sorbent solution and a heat source, thus replacing the electrical energy consumption of a mechanical compressor. For chilled water above 0°C, as it is used in air conditioning, a liquid H₂O/LiBr solution is applied with water as a refrigerant. Most systems use an internal pump that consumes little electricity. The main components of absorption chillers are shown in Figure 9. Absorption cycles are originating from the fact that the boiling point of a mixture is higher than of a pure liquid.

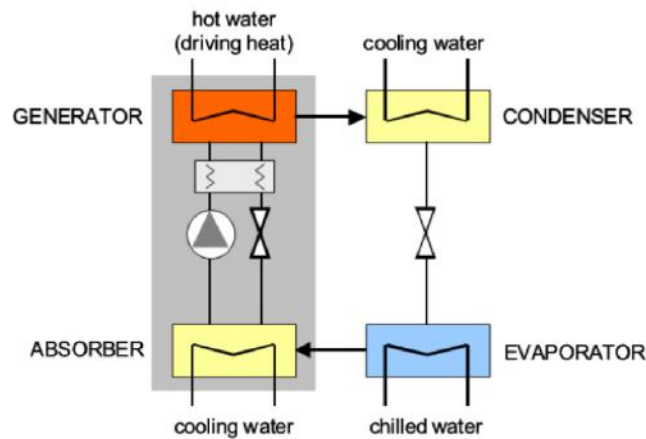

Fig.9. Scheme of an absorption chiller [1].

The thermal coefficient of performance (COP_{th}) is the useful cold ratio per heat unit:

$$COP_m = Q_{cold}/Q_{drive} \quad (1)$$

Where COP_m = thermal coefficient of performance, Q_{cold} is the useful cold, and Q_{drive} , driving heat.

An absorption cycle includes the following steps [1]:

The refrigerant evaporates in the evaporator, thereby extracting heat from a low-temperature heat source. This results in the useful cooling effect.

The refrigerant vapor flows from the evaporator to the absorber, where it is absorbed in a concentrated solution. Latent heat of condensation and mixing heat must be extracted by a cooling medium, so the absorber is usually water-cooled using a cooling tower to keep the process going.

The diluted solution is pumped to the components connected to the driving heat source, desorber, where it is heated above its boiling temperature, so that refrigerant vapor is released at high pressure. The concentrated solution flows back to the absorber.

The desorbed refrigerant condenses in the condenser, whereby heat is rejected at an intermediate temperature

level. The condenser is usually water-cooled using a cooling tower top reject the "waste heat".

The pressure of the refrigerant condensate is reduced and the refrigerant flows to the evaporator through an expansion valve.

Figure 10 shows the processes of the thermal absorption cycle.

The left arrangement presents the steam pressure as a function of the steam temperature in an absorption cooling cycle process [1]. On the right we can see the detailed functional scheme of a single-effect absorption chiller "Carrier" [9].

The required temperature of the heat source is usually above 85°C and typical COP values are between 0.6 and 0.8. Until a few years ago, the smallest machine available was a Japanese product with a cooling capacity of 35 kW (10 TR).

Recently, refrigeration products in the small and medium capacity range have entered the market. In general, they are designed to operate with low driving temperatures and therefore applicable to stationary solar collectors.

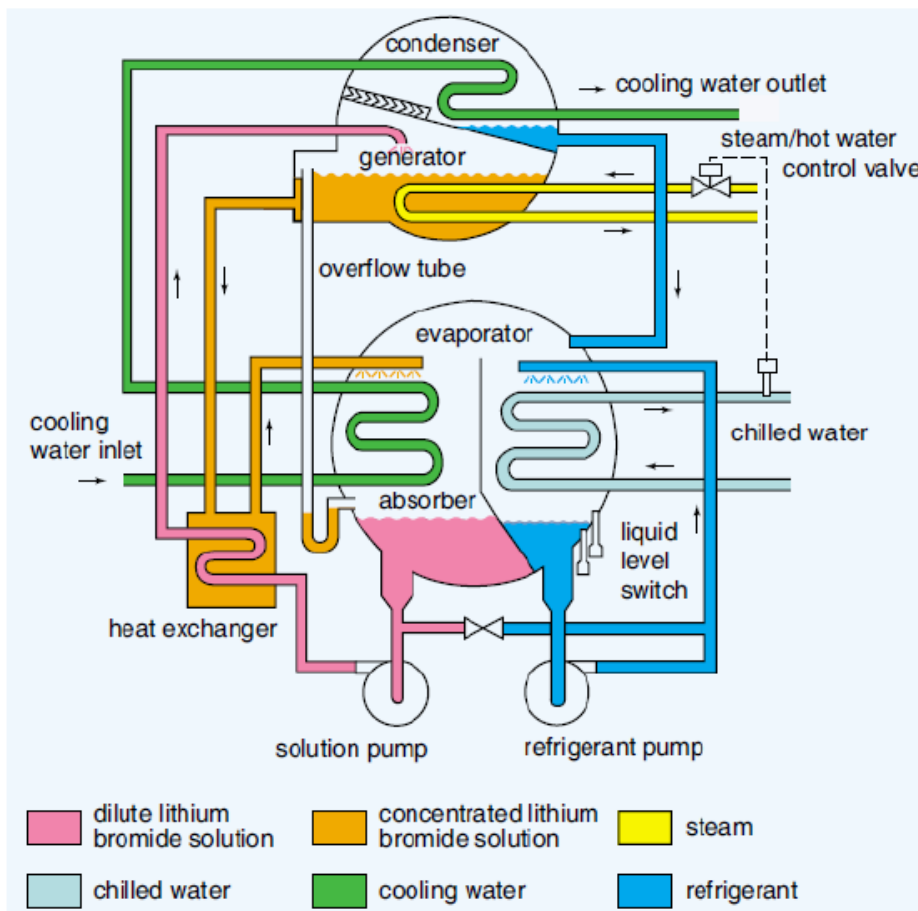
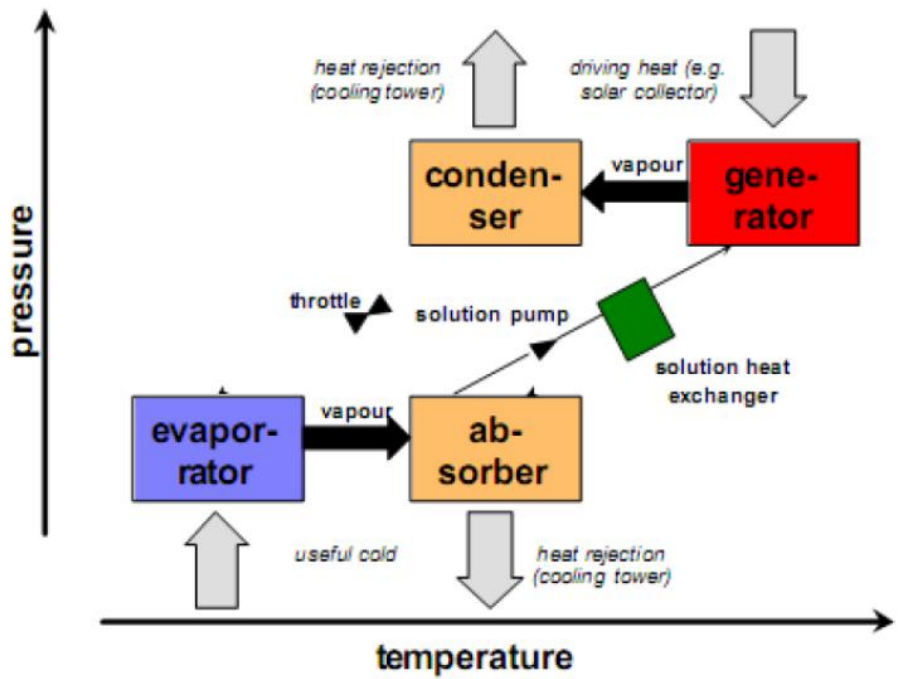

Fig.10. Thermal absorption cycle [9].

2.3.2. Conventional Compression Chiller

The most common cooling process applied in air conditioning is the steam compression cycle. The process

employs a chemical refrigerant, for example, R134a. A system's schematic drawing is shown in Figure 11.

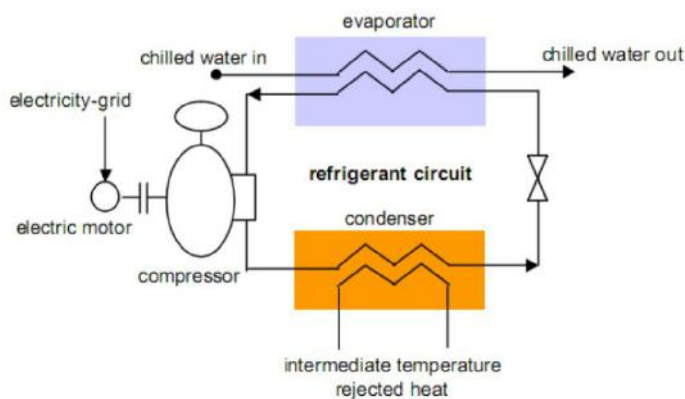

Fig.11. Schematic design of a steam compression chiller [7].

In the evaporator refrigerant evaporates at low temperature. Heat extracted from the external water supply is used to evaporate the refrigerant from the liquid phase to the gaseous phase.

External water is cooled than cooling energy becomes available. The key component is the compressor, compressing the refrigerant from a low to a higher pressure and temperature in the condenser [8].

For a conventional electrically charged steam compression chiller (COP) it is defined as follows:

$$COP = Q_c / P_{el} \tag{2}$$

Where Q_c = cooling capacity [kW] and P_{el} = electricity input [kW].

3. Case Study "Escolinha Tia Percila"

It is intended to equip the spaces of an elementary school with an air conditioning system assisted by solar energy. The school was founded in 1991 by the Street Children Foundation, a Swedish organization founded in 1993 to finance projects for needy children in several countries and in Rio de Janeiro, the favelas of Babilônia and Chapeu-Mangueira.

This case study was carried out within an NGO “Revolusolar” to obtain environmental benefits from solar energy, together with GIZ (German Corporation for International Cooperation) whose mission in Brazil is to strengthen the role of renewable energy sources.

At first, the technical and structural conditions of the school building were verified and then data was collected. The solar coverage rate was calculated using the HVAC Load software [14] determining the cooling load supporting the analysis of different SCS systems, the inventory and budget for the installation enabling the technical, economic, and environmental evaluation and the return on investment.

The building analysis provided information on energy efficiency potential. At the same time, measures were identified to reduce electricity consumption. The city of Rio de Janeiro is in Brazil’s southeastern with geographic coordinates 22°48’43” S and 45°11’40” W. It has a tropical savannah climate bordering a tropical monsoon climate. It presents long periods of heavy rain from December to March. Temperatures above 27°C are normal throughout the year and above 40°C are common during summer [10] as Table 1.

Table 1. Climate data for Rio de Janeiro.

Month	Temperature [°C]	Humidity [%]	Pressure [mb]	Precipitation [mm]	Sunshine-hours [h]
January	30,2	79	950,5	137,10	211,9
February	30,2	79	951,4	130,4	201,3
March	29,4	80	951,9	135,8	206,4
April	27,8	80	953,8	94,9	181
May	26,4	80	955,1	69,8	186,3
June	25,2	79	957,0	42,7	175,1
July	25,0	77	957,9	41,9	188,6
August	25,5	77	965,5	44,5	184,8
September	25,4	79	955,2	53,6	146,2
Oktober	26,0	80	952,6	86,5	152,1
November	27,4	79	951,5	97,8	168,5
Dezember	28,6	80	950,3	134,2	179,6
Average	27,3	79,1	953,6	89,10	181,82

The building has five floors with a terrace that offers space for solar thermal installations. The eleven rooms have a usable area of 240 m² and an average ceiling height of 2.8 m. The façade is southeast oriented and has a large window

area. The canteen is located on the first floor and the perforated bricks allow convection heat to leak through via stack-effect during meals. Figure 12.



Fig.12. “Escolinha Tia Percilia”, canteen and classrooms.

All equipment and characteristics of the school's building materials were inventoried and classified by age, condition and energy consumption using specific catalogues, making it possible to determine the building's energy efficiency. Classrooms and administration rooms have

windows, air conditioning and fans. The annual electricity consumption is 15,700 kWh and the annual cost is around €2,000 (2017). Refrigeration costs represents 61% as can be seen in Figure 13. Table 2 lists air conditioners installed and monthly consumption.

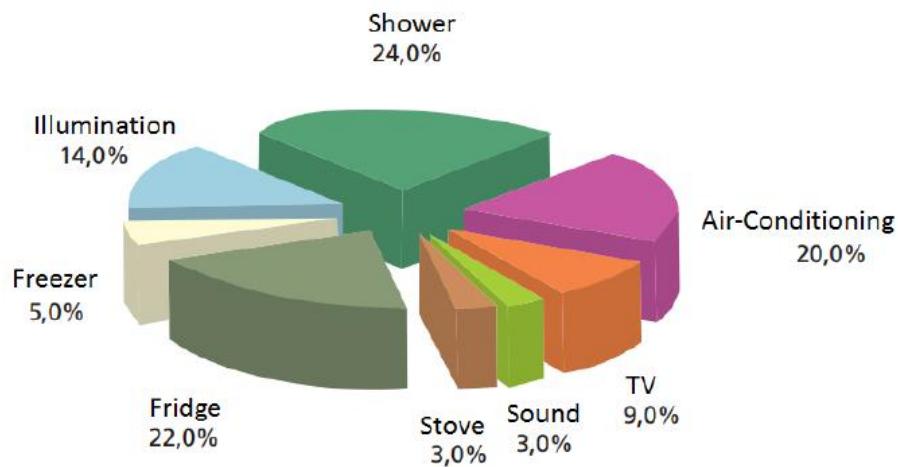

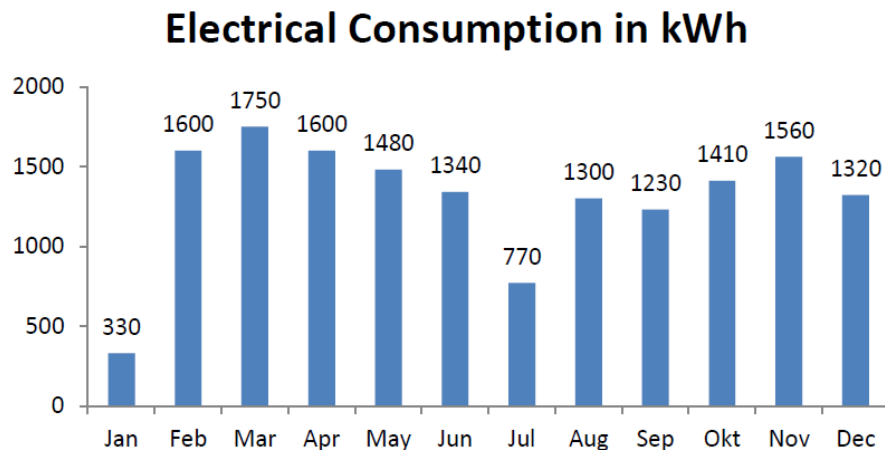

Fig.13. Electrical consumption by device in school and monthly Eletrical Consumption in kWh over the year in School Tia Percila.

Table 2. Air conditioning units installed and power consumption.

Room	Brandt	Model	COP (*)	Power (kW)*	Consumption (kWh)**	Service (h/m)***	Service (h)***	Consumption (kWh/month)
-2.1	Elgin	ERF30000	2.72	2.3	67.8	22.0	6	298
-1.1	Elgin	ERF30000	2.72	2.3	67.8	22.0	6	298
-1.2	Consul	CCO10B	3.02	0.7	20.4	22.0	6	90
0.1	Gree	GJE10AB	3.03	0.7	21.4	22.0	7	110
0.2	Elgin	ERF30000	2.72	2.3	67.8	22.0	6	298
2.1	Consul	CCM12D	3.08	0.8	23.9	22.0	7	123
Total								1217

*Manufacturer's technical data sheet; **Energy consumption researched "Procel" [11]; ***Daily operating time.

Weather and operating time impact electricity consumption which is low in January and July due to school holidays. In winter consumption is low. Cooling a dense environment in compliance with the NBR 16401-3 standard is a challenge. The users' misbehaviours leads to the waste of energy, hence education and awareness are needed. There must be a renewal of the air to avoid the concentration of toxic gases and odors. Due to the lack of resources to install exhaust fans, the programmed opening of the windows was adopted, and the consequent thermal loss was considered in

the calculation of the cooling load. In the canteen, the air is renewed through perforated bricks. Analysing the building's thermal behaviour, the calculation obtained information about the maximum cooling demand during the hottest average day. The thermal load was calculated using the building simulation program "HVAC Load Explorer" [14]. The input data for the external and internal cooling load must be defined and added. The main influencing factors are shown Figure 14.

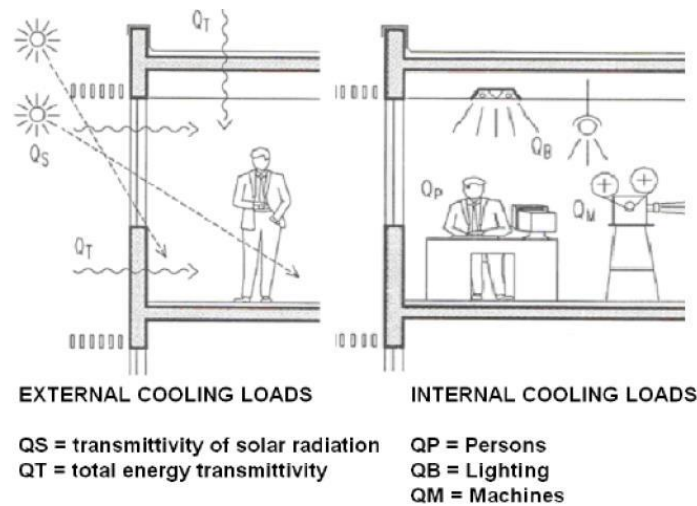

Fig.14. External and internal cooling loads [12].

Table 3 lists the dimensions of the spaces considered. Table 4 shows information for the case of 0.4% of unattended days corresponding to the worst probability [7] of meteorological data input “Escolinha Tia Percila”, Rio de Janeiro.

Table 3. Relevant spaces for the cooling load calculation and, meteorological data input [7].

No.	Room	a(m)	b(m)	h(m)	A(m ²)	V(m ³)	Latitude	29,695
-2.1	Classroom	6	6	2.4	36.0	86.4	Longitude	43,17W
-1.1	Classroom	6	6	2.9	36.0	104.4	Altitude	50m
-1.2	Classroom	4.4	6	2.9	26.4	76.6	Pressure	101,22kPa
0.1	Office	4.4	3.3	2.85	14.5	41.4	Average Wind Velocity	4,8m/s
0.2	Laboratory	5.7	6	2.85	34.2	97.5	Wind Direction	150° (0 N; 50W)
2.1	Office	4.3	6	2.7	25.8	69.7	Dry-Bulb Temperature	37,3°C
							Wet-Bulb Temperature	25,4°C
							Relative Humidity	79%

The total floor space of 170 m² and the average ceiling height of 2.76m was considered. The school has 5 floors covered by external walls with thermal transmission factor of 1,8 W/(m²K) and windows of 2,7 W/(m²K). The windows are obstructed mainly North and South; have no curtains. The following data was set within the HVAC Load Explorer, Table 4.

Table 4. Software extract "HvacLoadExplorer" - Layers of the outer wall.

Layer	Sp Heat (Btu/(Lb.F))	Conductivity (Btu.in/(hr.ft ² .F))	Thickness (In)	Density (Lb/Ft ³)
Plaster	0,64	0,24	0,050	124,9
ceramic brick	0,52	0,22	0,12	99,9
Plaster	0,64	0,24	0,050	124,9

The ground floor has a constant temperature of 20°C. Solar installations on the terrace and a tree provide shade. Considering the air renewal of 30 m³/h per person, 110 students demand 3,300 m³/h. With a total volume of 469 m³ in the spaces, air renewal is 7.0 l/h. The classrooms are occupied from 7h30-11h00 a.m. and 1h30-5h30 p.m. The two offices from 7h30-5h30 p.m. Considering an emission of 97 W per person, 110 people produce at a thermal load of 10.7

kW, lighting 15 W/m² in 170 m² producing 2.6 kW. Other devices produce 3.6 kW totalizing 17 kW. In Brazil the temperature is set between 18- 20 °C. The simulation was performed with two internal temperatures, 20 °C and 26 °C. The projected internal temperature of 26 °C. The high cooling load between the two temperatures stands out according to Table 5. The internal air temperature (Ti) is the most obvious indicator of thermal comfort [7].

Table 5 - Conditions of internal thermal comfort in relation to summer ambient temperatures [13].

Internal Conditions	Relative Humidity (%)	62 56 50 44 66 60 54 48 70 64 58 52													
		Wet-bulb Temperature (°C)													
External Temperature	Dry-bulb Temperature (°C)	19,5	19	18,5	18	20,5	20	19,5	19	21,5	21	20,5	20		
	Dry-bulb Temperature (°C)	24,5	25	25,5	26	25	25,5	26	26,5	25,5	26	26,5	27		
	Dry-bulb Temperature (°C)	29				32				35					

Figure 15 shows the daily thermal behaviour of the building in the worst-case scenario: Total cooling load (Btu/h) with Ti=26 °C and 20 °C during 24 h. summer. With an internal temperature of Ti = 26 °C, the maximum cooling load is 125,560.2 BTU/h (~36.8 kW; with Ti=20 °C, 157. 687.9 BTU/h (~46.2 kW). At the end, the total cooling load is compared with Ti = 26 °C and Ti=20 °C.

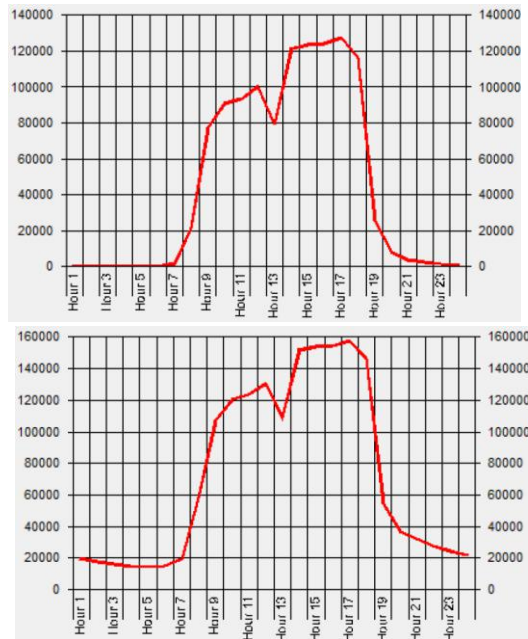

Total Cooling (kW)

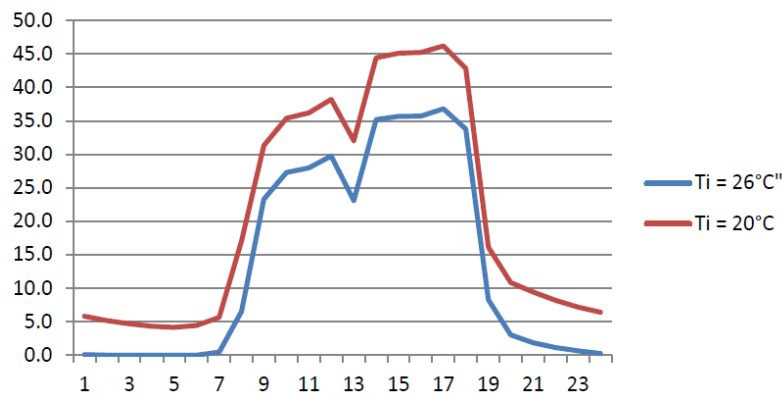

Fig.15. HVAC Load Explorer Output.

The Simulation for the different indoor air temperatures shows that the total cooling load increases up to 9.6 kW for a temperature variation $\Delta T_i = 4^\circ\text{C}$. Figure 16 shows the different thermal behavior of both indoor air temperatures during a summer day (worst-case scenario). Table 6 shows the results of the maximum cooling loads for the two ambient temperatures.

Table 6. Maximum cooling loads to the two ambient temperatures.

Indoor Set Point Temperature T_i [$^\circ\text{C}$]	Maximum Cooling Load [kW]	Specific Cooling Load [kW/m^2]
20	46.2	272
26	36.8	216

The applied system is like an auditorium at the University of Guaratinguetá [3]. It is a closed cycle process combining different subsystems as shown in Figure 13 and technical characteristics related to the simulated cooling load for a $T_i=26^\circ\text{C}$.

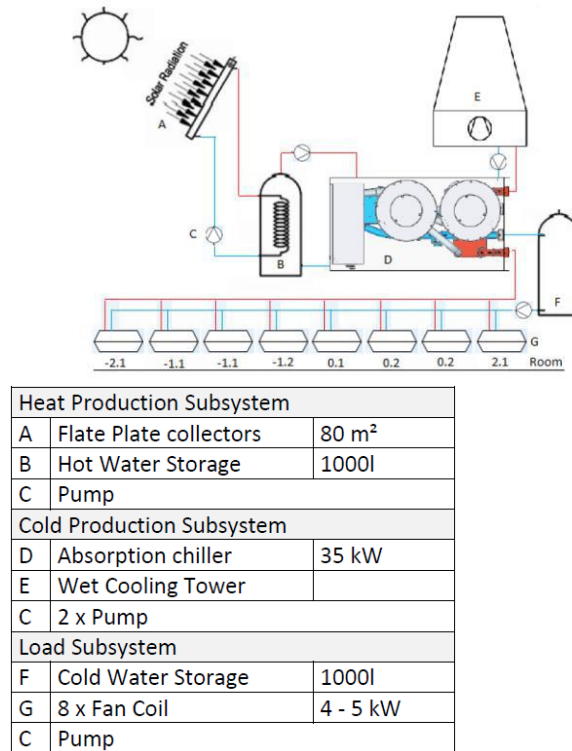

Fig.16. Schematic diagram of the system selected for the school and technical components of the different subsystems.

The heat production subsystems mainly consist of 80 m² solar thermal collector fields, which serve the hot water tank with inlet and outlet temperatures of 88 °C and 83 °C. The cold production system contains a 35-kW absorption chiller and a cooling tower. The thermal compressor of the absorption chiller is served by the heat provided by the hot

water tank. The load subsystem consists of a cold-water tank, the distribution system and 8 fan coil units. Figure 17 shows that cooling throughput meets demand during the day. At 12:00 the cooling capacity is almost twice as high as the demand. During the day the cooling load and solar gain occur simultaneously.

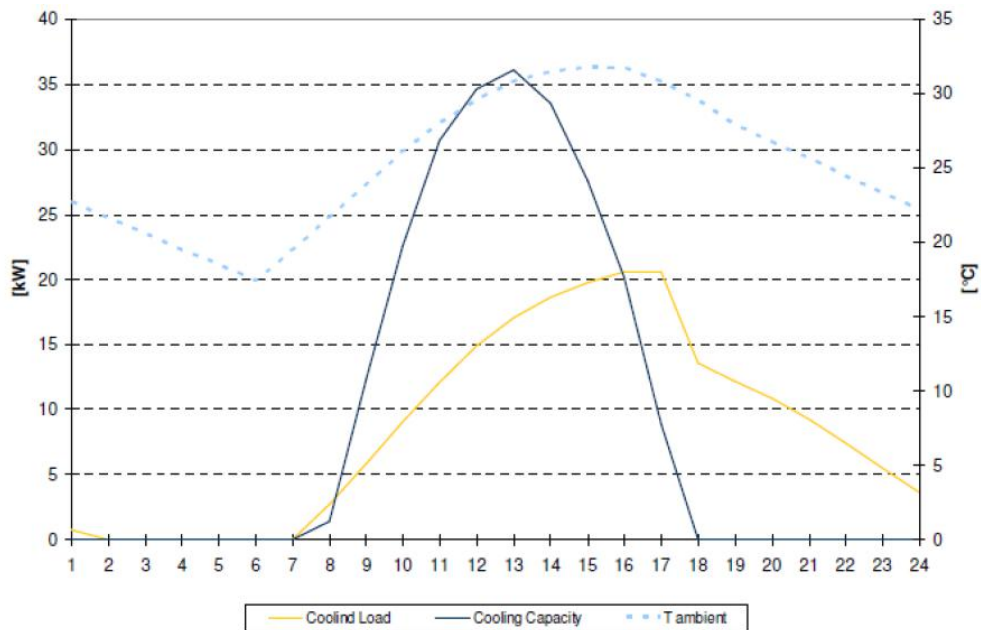

Fig.17. Expected correlation between cooling demand and yield in summer [3].

Figure 18 shows the total monthly demand for expected cooling and available thermal energy production (8760 h) in the case of the University of Guaratinguetá. The

solar yield was calculated with a constant average daily collector efficiency of 0.38 m² and a constant chiller COP of 0.7 [3].

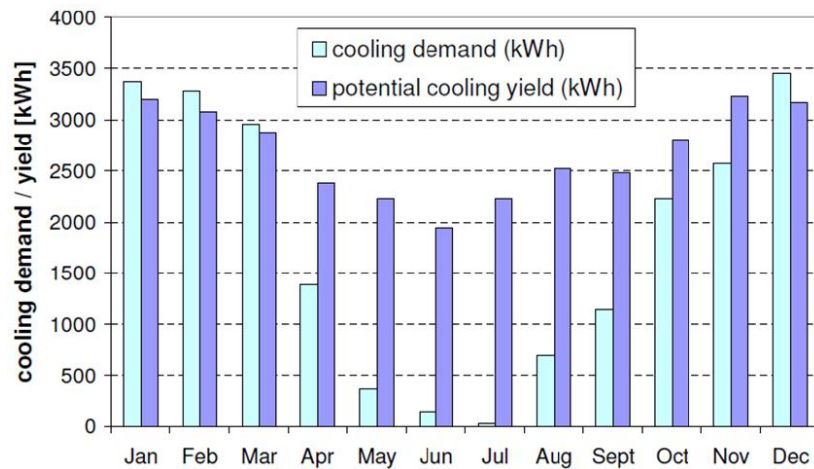

Fig.18. Total monthly cooling demand.

Predicted total monthly cooling demand and available yield of thermal energy (8760 h). Solar yield is calculated with a constant daily average collector efficiency of 0,38 m² collector array and a constant Chiller COP of 0,7 [4].

From table 7, the investment cost for the cooling system studied is R\$ 3,000/kW. The cooling system has been sized to cover a thermal load of 35 kW. R\$ 105,500 were the total investment costs. The return on investment is 15.8 years to 20 years.

Table 7. Electricity consumption and operating cost between the existing and the proposed system.

Electricity Consumption & Operation Cost		
Component	Solar Assisted System	Existing Cooling System
4 x Water Pumps	360 W	
Wet Cooling Tower Fan	280 W	
35 kW Absorption Chiller	210 W	
8 Fan Coil Units	600 W	
5 x Window Air-Conditioner		35.8 kW
Total	1450 W	35.8 kW
Total (1 Year)	2152 kWh*	9577 kWh**
Operation Cost (1 Year) by 0.898 R\$/kWh (RJ)	1930 R\$	8600 R\$

To estimate emissions of CO₂ per kWh of cold produced, a conversion factor of 0.28 kg CO₂ per kWh of electricity was applied [1], Table 8.

Table 8. CO₂ savings per year calculated with conversion factor of 0.28 kg CO₂ per kWh of electricity.

Electricity Consumption per Year (kWh)	CO ₂ – Emissions (kg)
Solar Assisted System	603
Existing System	2682
CO ₂ Saving per Year	2079

The substitution for a SCS system presents an environmental gain in the emission of CO₂ and elimination of greenhouse gases by ecological refrigerants. Water consumption of the wet cooling tower, in this case 50 l/d can be gotten by treated rainwater.

III. RESULTS

The low operating cost of SCS compensates for investment in cooling buildings and contributes to reducing the consumption of electricity from non-renewable sources by increasing its share in the energy grid, encouraging the Government to practice sustainable public policies in accordance with ESG standards. In this way, SCS proves to be a sustainable energy alternative in providing environmental conditioning of buildings using solar energy. SCS and PV systems combined make up one of the furthered technologies, as the current trend is directed towards electrical supply in all facilities. Furthermore, the need of back systems is in high demand and will expand to general building technologies [15].

REFERENCES

- [1] Fraunhofer Institute for Solar Energy Systems ISE. Solar Cooling in Brazil - Technology study. Freiburg, Germany, 2009.
- [2] IEA. Solar Heating & Cooling Program, Available online: <https://www.iea-shc.org/solar-academy>, Webinar, (accessed on 11/10/2023).
- [3] Felix, R. Technical and Economic Assessment of Solar-Assisted Air-Conditioning in Brazil. M.Sc. Thesis, PUC, Brazil, 2010.
- [4] Solair, Requirements on the design and configuration of small and medium sized solar air-conditioning applications – Guidelines, Available online: <https://www.solair-project.eu> (accessed on 11/10/2023).
- [5] Hans-Martin, H. TASK 38 - Solar Air Conditioning and Refrigeration, IEA SHC, Germany. 2012.
- [6] Douglas, R., Estudo Teórico da Otimização de Refrigeradores Térmicos por Adsorção. Ph.D., Thesis, UFPB, Brasil, 2008.
- [7] ASHRAE, ASHRAE Terminology of HVAC&R, Available online: <https://www.ashrae.org/technical-resources/authoring-tools/terminology> (accessed on 11/10/2023).
- [8] Uli, J.; Daniel, M., Keeping cool with the sun, *International Sustainable Energy Review*, 2012, Volume 6, p.p. 28-30.
- [9] Carrier United Technologies, Lithium Bromide Absorption Chiller, Technical Data Sheet 16JLR. T-16JL/R-0710-01(E)-CHK, 2023.
- [10] INMET, Dados meteorológicos médios, Brasil, Available online: <https://portal.inmet.gov.br>. (accessed on 11/10/2023).
- [11] Procel, Participação dos eletrodomésticos no consumo de eletricidade, Eletrobras, Brasil, 2023.
- [12] ABNT, Instalação de ar-condicionado – Sistemas centrais e unitários, Standard NBR16401, Brasil, 2008.
- [13] Arone, H. Análise computacional da demanda energética de climatização de edifício, B.Sc., Thesis, UNB, Brasil, 2005.
- [14] CEAT. HVAC Load Explorer, Available online: <https://hvac.okstate.edu/hvac-load-explorer.html> (accessed on 11/10/2023).
- [15] Parmar, A. A., G Babu, R., & Junare, S. O. (2022). Differentiation of high velocity ammunition type from Gunshot Residue (GSR) metal element originating from different firearm. In *International Journal of Chemistry, Mathematics and Physics* (Vol. 6, Issue 2, pp. 18–23). AI Publications. <https://doi.org/10.22161/ijcmp.6.2.2>
- [16] Wey, Z; Chengz, L; Lin, L; Hongxing, Y. Current status of research on optimum sizing of stand-alone hybrid solar–wind power generation systems; *Applied Energy*, V. 87, Issue 2, February 2010, pp. 380-389. <https://doi.org/10.1016/j.apenergy.2009.08.012>